

ROV/AUV Side Scan

SeaKing Side Scan Sonar



Easy to integrate into sub-sea vehicles

The unit is supplied as two separate transducers and an electronics module suitable for integration into most ROV's and AUV's. The ARCNET or RS232 communications protocols allows it to be operated with other Trittech SeaKing underwater sensors such as scanning sonars, profilers or bathymetric systems over a single communications link to the surface.

The SeaKing ROV Mounted Sidescan Sonar System is an extremely compact and cost effective high definition sidescan sonar designed for a wide range of seabed survey and inspection duties.

Combining the very latest in digital sonar technology with industry leading transducer design and digital CHIRP signal processing techniques dramatically improves range resolution and generates sonar images of unprecedented clarity.

The ROV Sidescan can be connected to a Surface Control Unit (SCU) or a normal PC/laptop through a SeaHub. In addition to displaying the sidescan data the system can record and combine the data with positional information from an external GPS sensor. This allows accurate fixing of features on the sonar scan.

The logged sonar data can be exported to a variety of standard formats include XTF, CSV, GeoTIFF or Google Earth KMZ format.

Benefits

- Robust, compact, reliable design
- Easy system integration
- Export to XTF, TIFF, GeoTIFF
- Export to Google Earth KMZ

Features

- 4000m depth rating
- Cost effective design
- Low power usage
- High data rate
- Compatible with SeaKing range
- High and low frequency options

Applications

- Deep water surveys
- Coastal surveys
- Military mine counter measures
- Shipwreck location and survey
- Pipeline and route surveys
- River, harbour and canal surveying

Specification

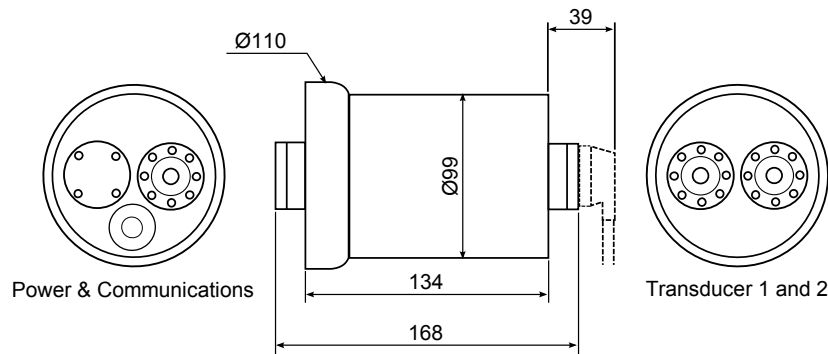

Not to scale, dimensions in mm.

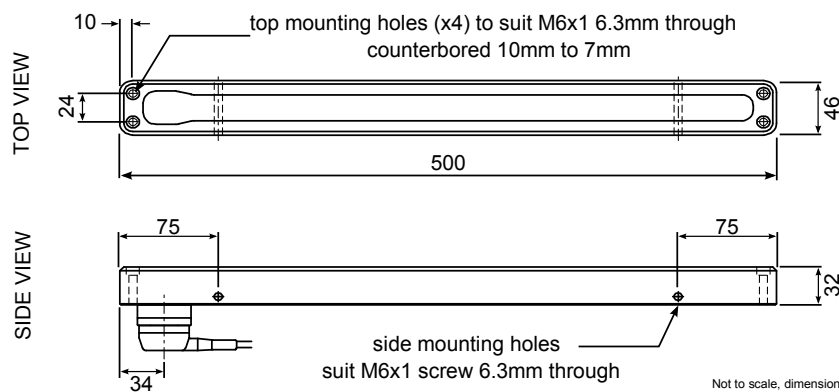

Not to scale, dimensions in mm.

Acoustic	Low Frequency	High Frequency
Frequency	325kHz	675kHz
Beamwidth	30° vertical, 1° horizontal	30° vertical, 0.5° horizontal
Maximum range	200m	100m
Pulse length	400µs	200µs
Note	The ROV Sidescan is supplied as either Low Frequency or High Frequency and is not switchable.	

Electrical and Communication	
Maximum range	20 – 36V DC at 12VA
Pulse length	ARCNET, RS232
Note	ARCNET: 156kbit·s ⁻¹ or 78kbit·s ⁻¹ RS232: 115.2kBd

Software	
Software	Tritech Seanet Pro or low level direct command control
Data log format	Tritech V4Log as standard. Export to XTF, TIFF, GeoTIFF and Google Earth KMZ via converter

Acoustic	Electronics Pod	Transducers
Weight in air	2.5kg	1.4kg (each)
Weight in water	1.6kg	0.54kg (each)
Depth rating	4000m	
Connector	Tritech 6-pin waterblock	

Specifications subject to change according to a policy of continual development.

Document: 0374-SOM-00012, Issue: 02